

FOUR AXLE By TRAVIS

Travis Body & Trailer, Inc.
13955 FM 529 * Houston, TX 77041
800.535.4372 or 713.466.5888
www.travistrailers.com

Frame-type with WAVE sidewalls



Far Superior
Dump Stability



Frameless with AERO-LITE sidewalls



The **FOUR AXLE TRAILER** by Travis does not defy logic, it is logic. Why not meet the bridge law without extra trailer length? By working with selected state and federal bridge law authorities, Travis has configured a trailer that is Federal Bridge Law legal to 80,000 pounds but with a 26 ft. trailer (State laws may vary). You say, this has been done before. Well, not with a 10,500 pound trailer!

We can build it as a frameless or a frame-type trailer and with any of our popular body styles, the Classic, the Aero-Lite or the all new WAVE. The logic is simple, full payload capabilities, increased maneuverability and greatly improved dump stability. You just might want to take a closer look at this one.



KEY FEATURES & BENEFITS OF THE FOUR AXLE TRAILER

Trailer Body – 26 ft
Improved Dump Stability and maneuverability compared to Longer 39' tandem axle trailers.

Two Rear Axles – typical set up is two 25,000 pound rated axles/ suspensions.

Two Front Axles – 3,500 pound capacity, liftable axles, air ride suspension.

See detailed Federal Bridge Law analysis (State Laws may vary).

SST
TECHNOLOGY

In the world of trailers,
look to the **LEADER!**

FIFTH WHEEL
 SET FORWARD 20"
 OF TANDEM C/L
 16" KP SET
 206" WHEEL BASE

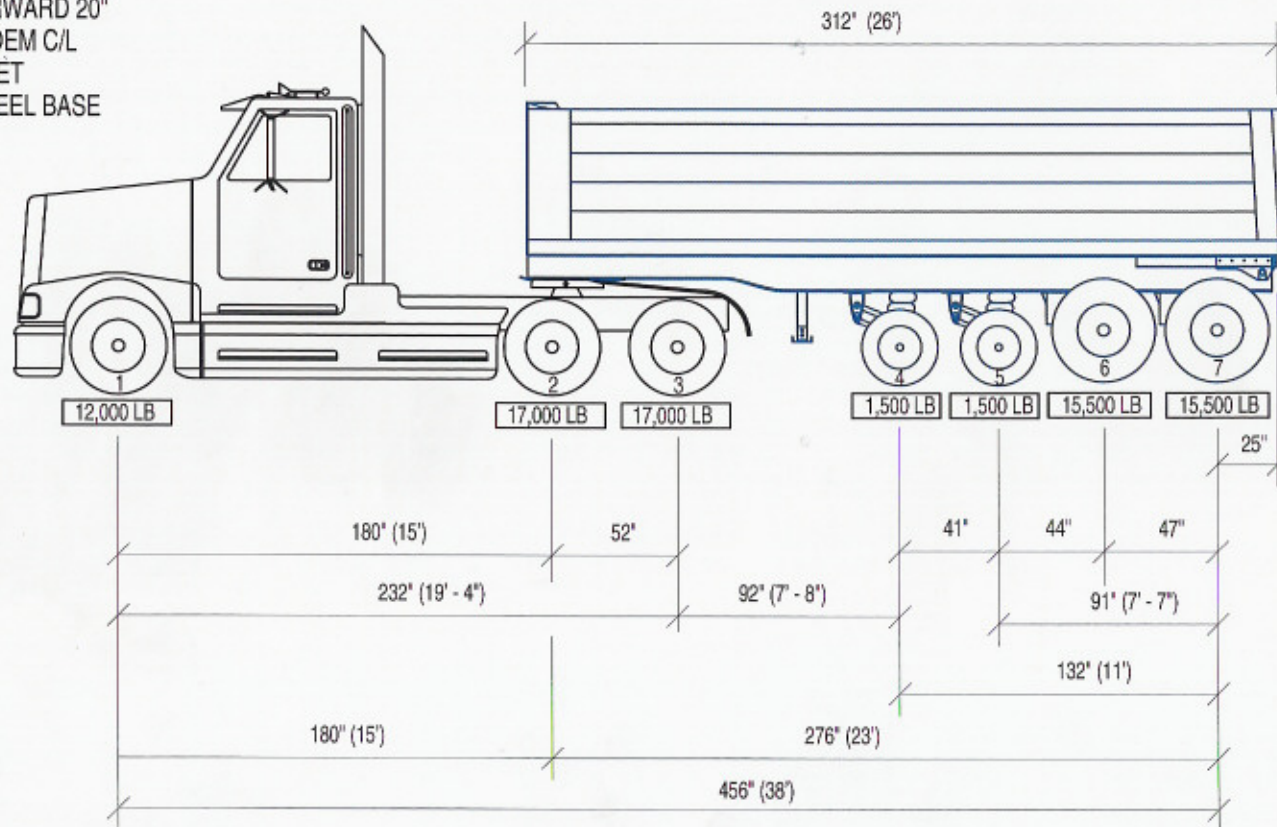

80,000 LB. GROSS
 15,000 LB. TRUCK
 10,500 LB. TRAILER

54,500 LB. PAYLOAD

AXLES	ACTUAL	ALLOWABLE
6 - 7	31,000	34,000
5 - 7	32,500	34,000
4 - 7	34,000	49,500
2 - 7	68,000	68,000
1 - 7	80,000	80,000

		MODEL: TLITE 4 AXLE TRAILER	
		FEDERAL BRIDGE ANALYSIS	
MATERIAL:		QTY REQ:	BLANK:
DRAWN	JRB 2/25/03	SCALE:	DRAWING NO.
CHK'D	JRB 2/25/03	REF:	BRG4DSHOW